

TECHNICAL DATA/SPECIFICATION

MODEL: SRE-5000 ELAN STRAIGHT RAIL STAIRLIFT, PRIVATE RESIDENCE ONLY

RATED LOAD: 300 LBS, ONE PASSENGER

POWER SOURCE: 24 VOLT DC COMPRISED OF (2) 3.2 AMP/HR
12 VOLT SEALED BATTERIES
100-240 VOLT AC 1 AMP, 24 VOLT DC 1 AMP
CONTINUOUS MONITORING CHARGER.

RATED SPEED: 21 FPM (0.107 m/s) MAX.

DRIVE: 24 VOLT DC FRACTIONAL HORSEPOWER DIRECT DRIVE,
WORM GEAR MOTOR.

SUSPENSION: RACK & PINION - INTEGRATED 8DP GEAR RACK
ON RAIL WITH SPUR GEAR ON THE OUTPUT SHAFT
OF GEARBOX.

BRAKING: DYNAMIC MOTOR BRAKING THROUGH THE MOTOR
CONTROLLER, WORM GEAR, ELECTRO-MECHANICAL
MOTOR BRAKE AND OVERSPEED PROTECTION.

CONTROLS: CONTINUOUS PRESSURE ROCKER SWITCH LOCATED
ON THE ARMREST AND WALL MOUNTED CALL/SEND
CONTROLS LOCATED AT BOTH THE TOP AND BOTTOM
LANDINGS.

ANGLES: 22° TO 52°, RIGHT OR LEFT HAND ORIENTATIONS

TERMINAL LIMIT SWITCHES AND TOP FINAL LIMIT STATE.

SRE-5000

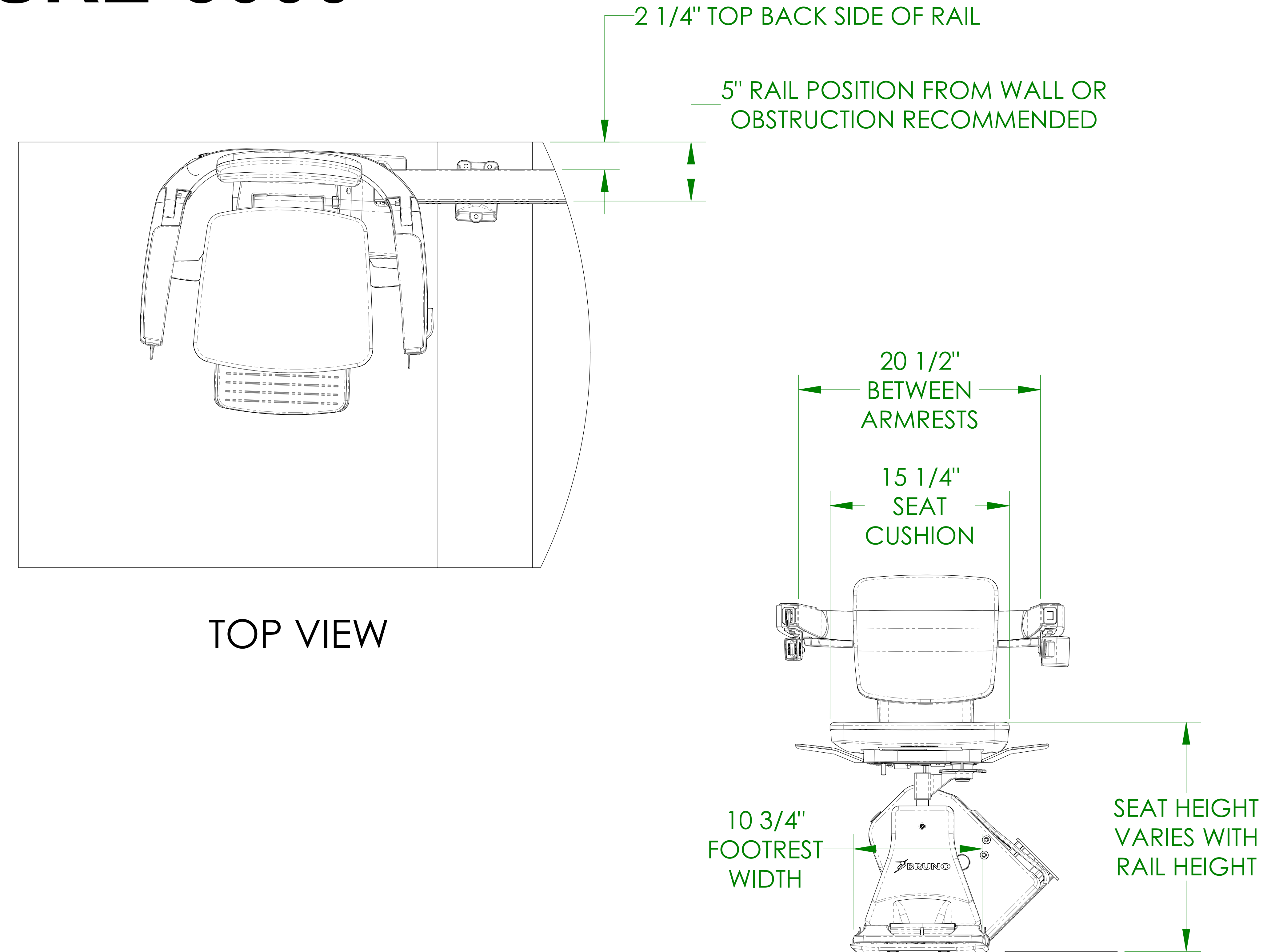

TOP VIEW

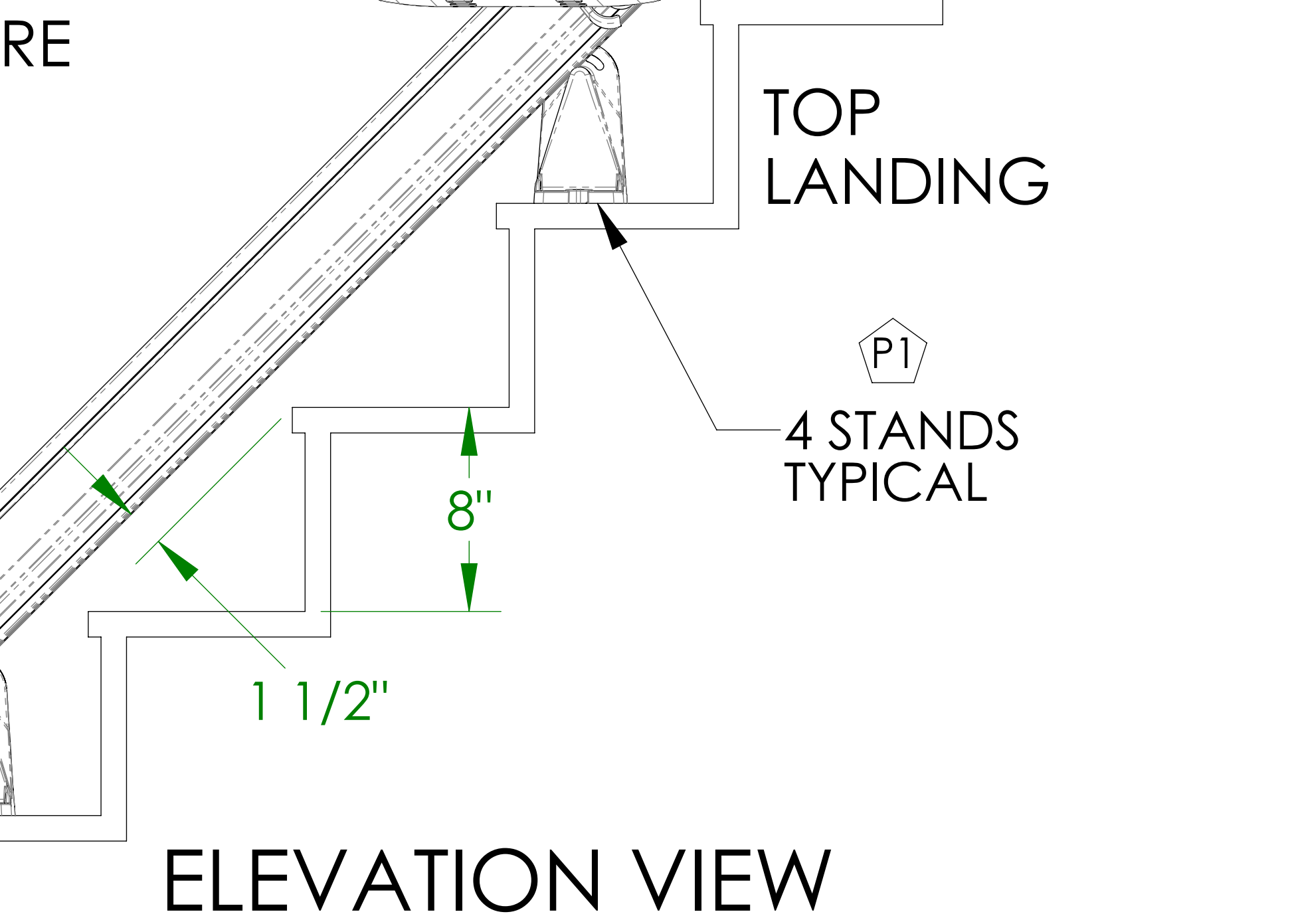

ELEVATION VIEW

LOWER LANDING EXTENSION DIMENSIONS ARE
BASED ON 45° RAIL SLOPE ON AN
8" 1ST RISER HEIGHT. DIMENSIONS WILL VARY
BASED ON SLOPE AND RISER HEIGHT.

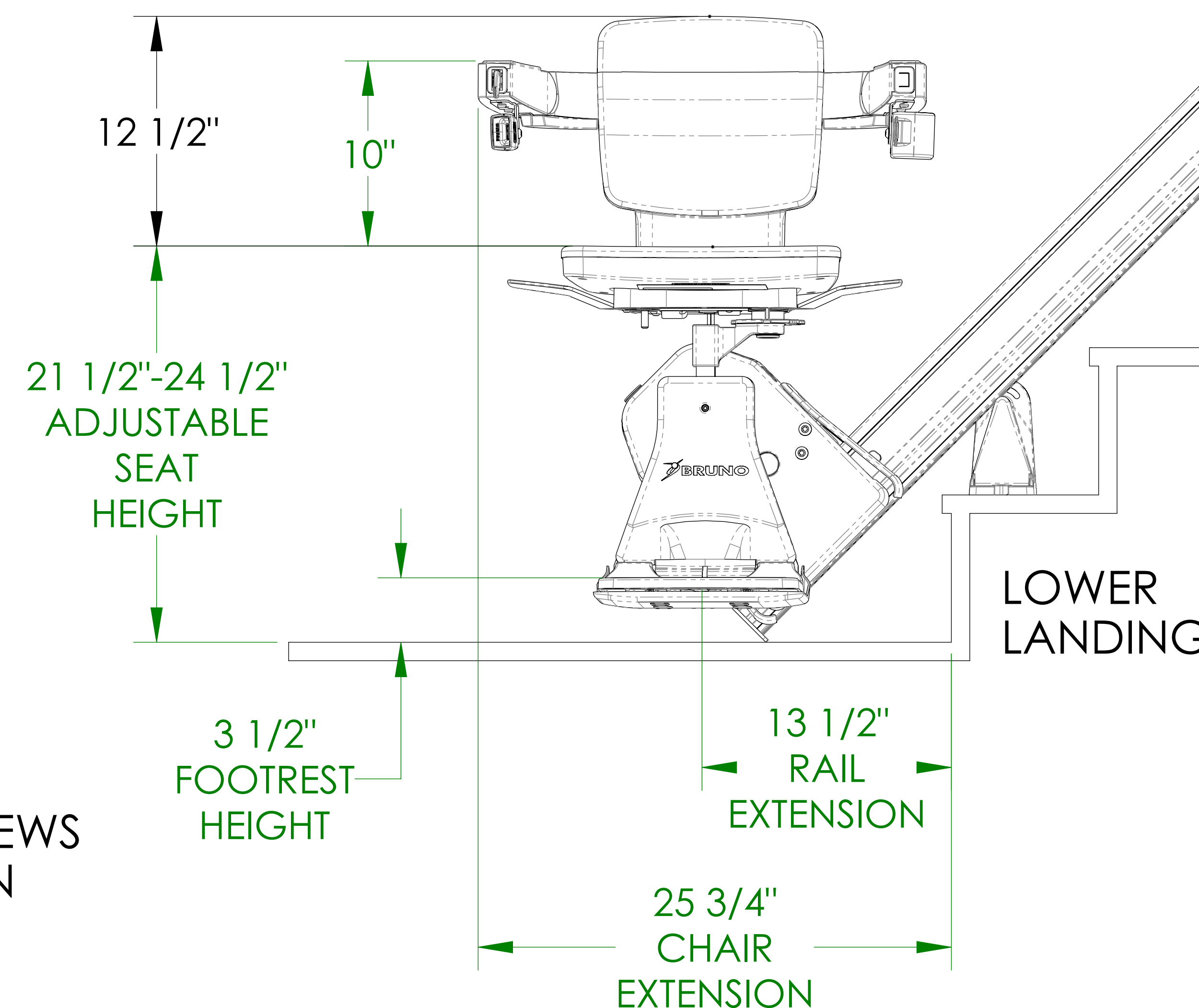

LOWER LANDING

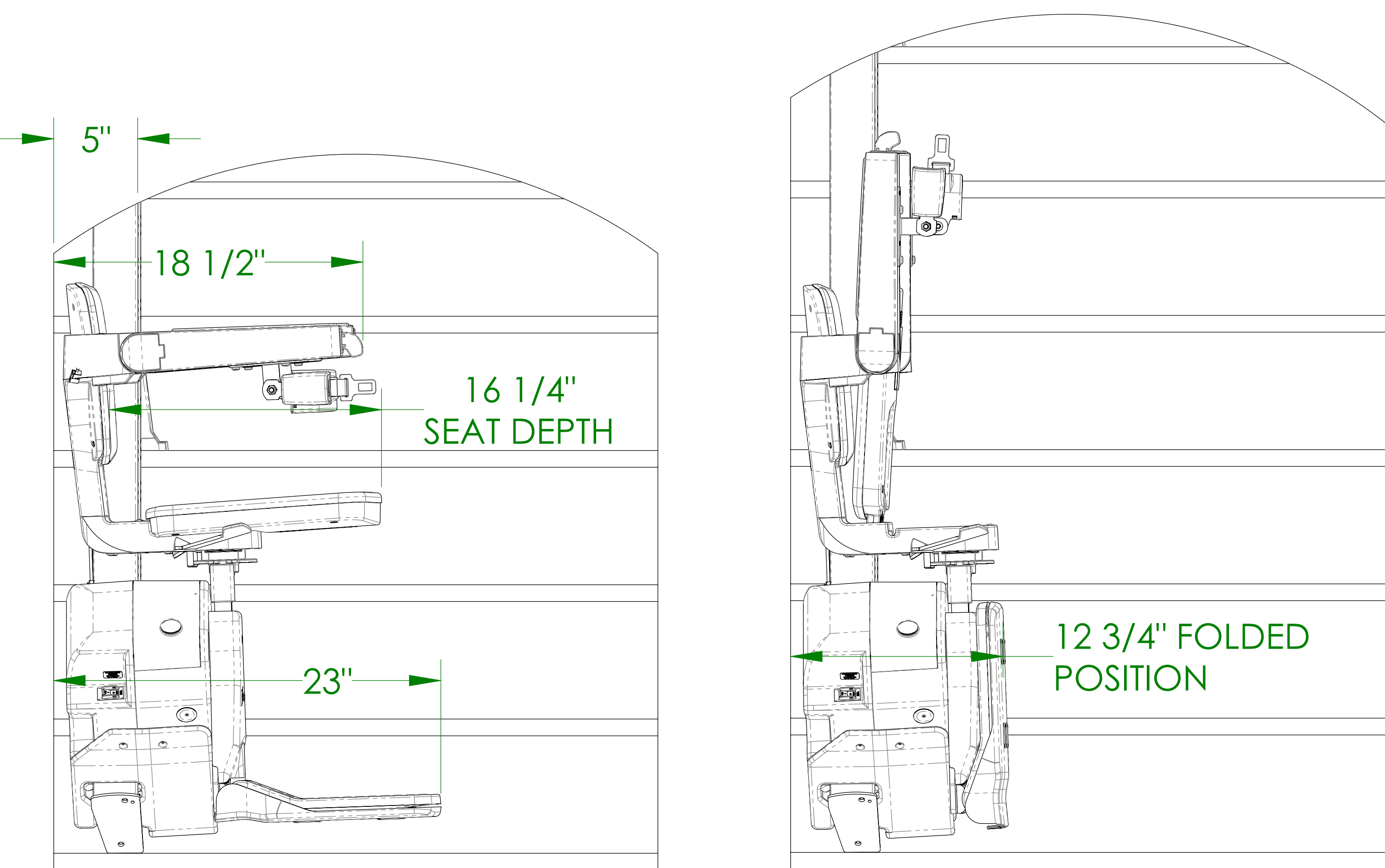

SIDE VIEWS

DIMENSIONS SHOWN IN SIDE VIEWS
ARE BASED ON 5" RAIL POSITION
FROM WALL OR OBSTRUCTION

1780 EXECUTIVE DRIVE
OCONOMOWOC, WI 53066
WWW.BRUNO.COM



©Bruno Independent Living Aids, Inc.

ILS-01614
SHEET 1 OF 3
REV. P1 (8330)(04/13/26)(BHM)

SRE-5000

DISTANCE FROM WALL - SEAT SWIVELED

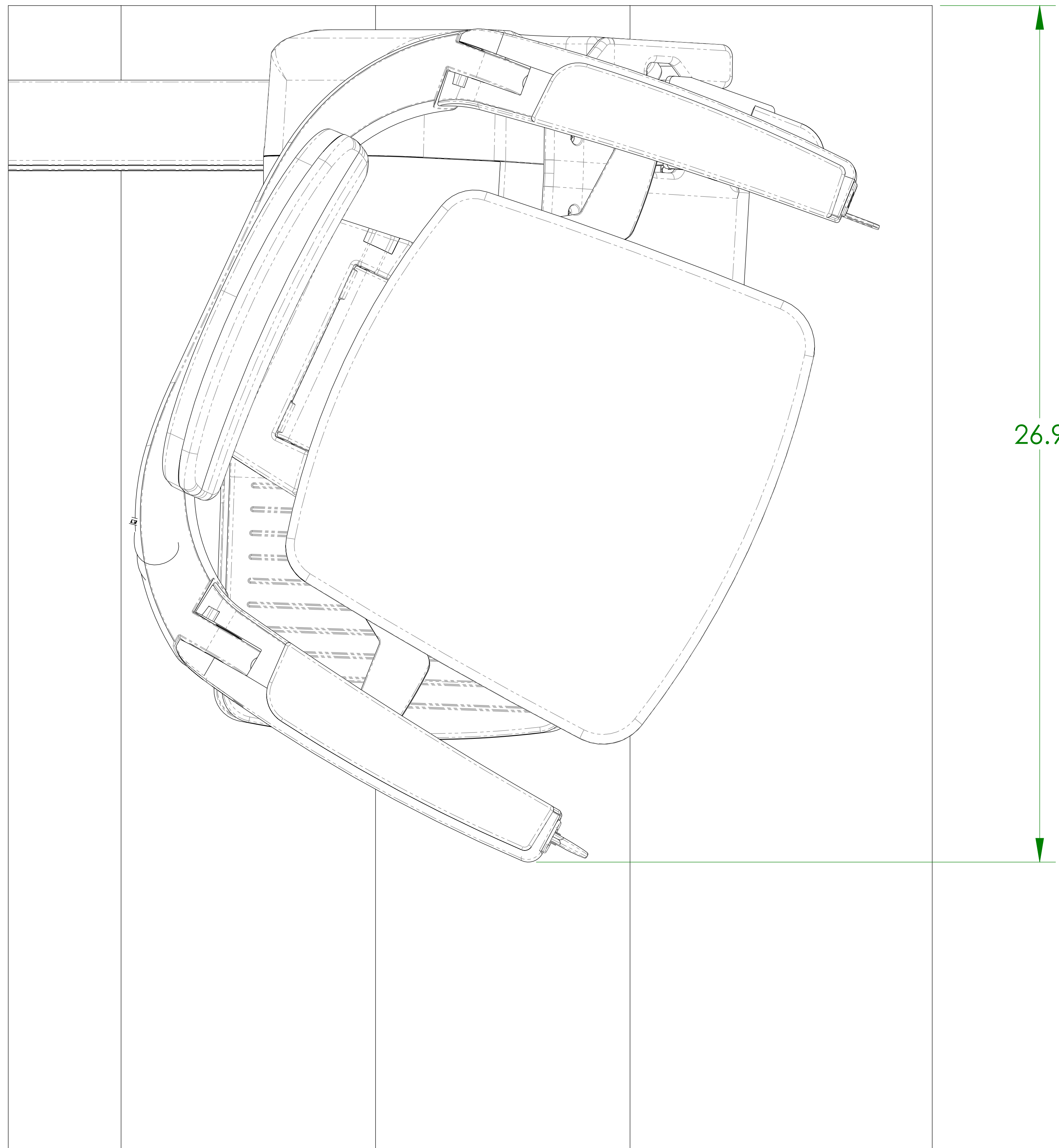

SEAT SWIVELED 67°

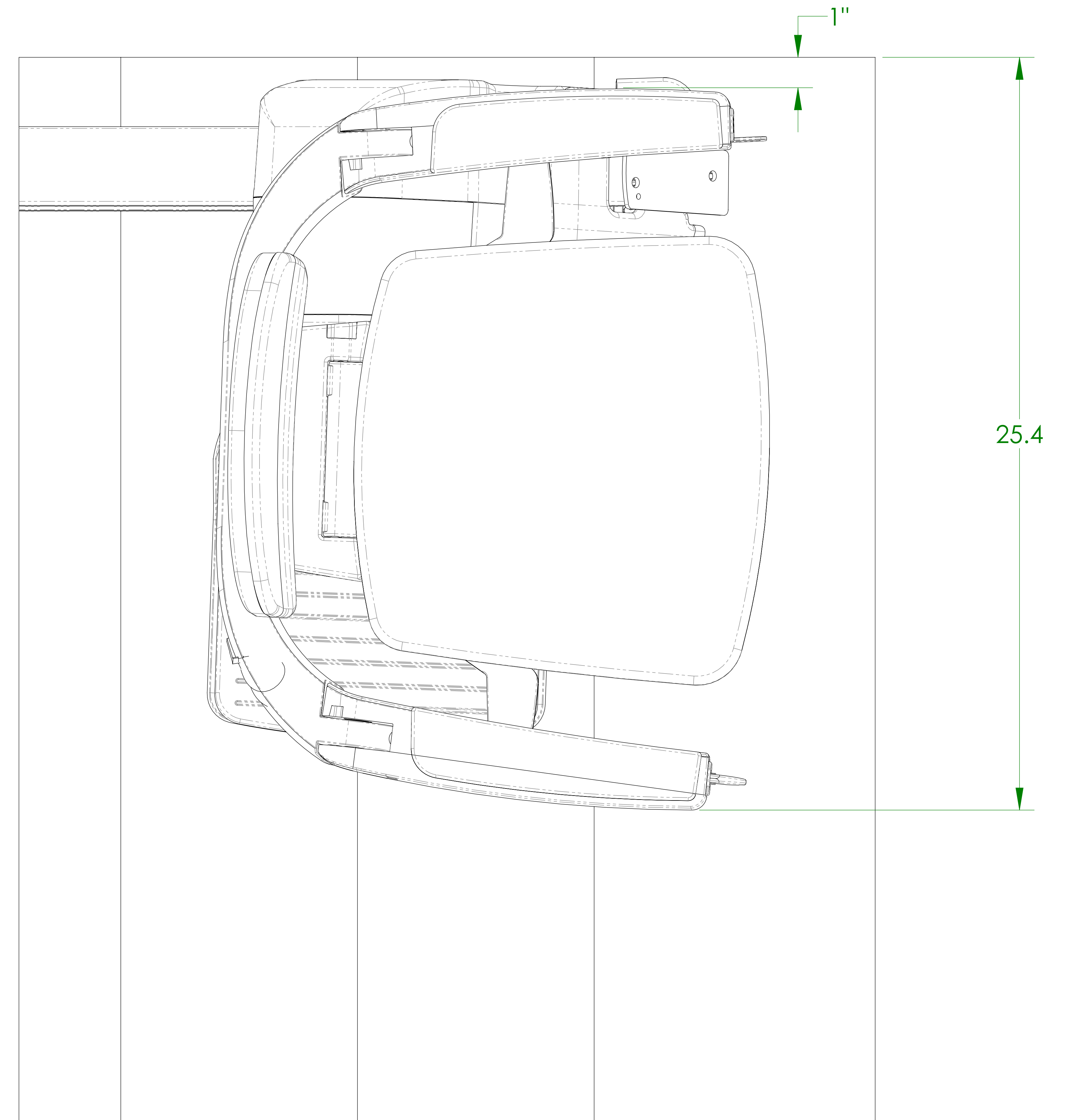

SEAT SWIVELED 90°

1780 EXECUTIVE DRIVE
OCONOMOWOC, WI 53066
WWW.BRUNO.COM

SRE-5000 FOLDING RAIL

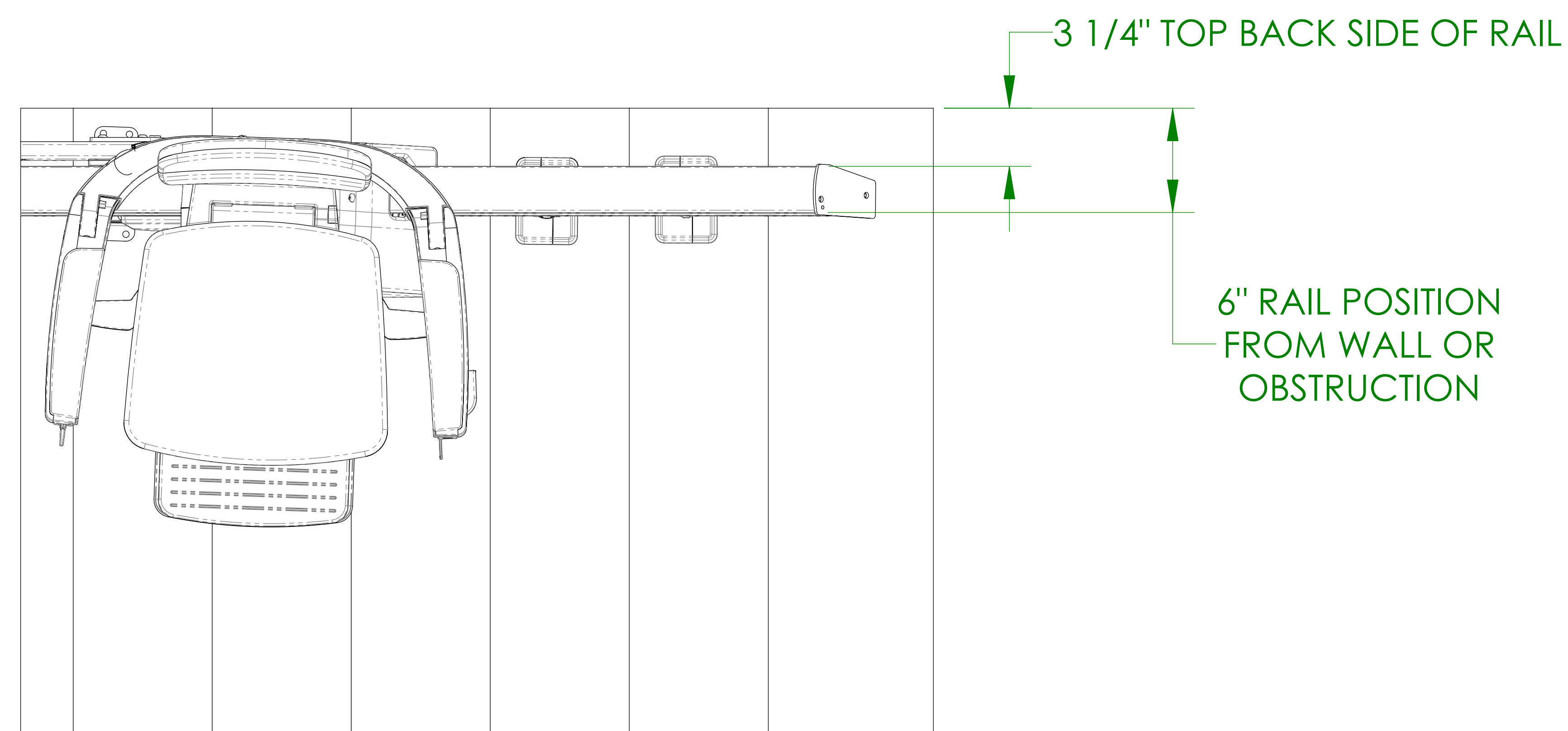

TOP VIEW

AUXILIARY ELEVATION VIEW
RAIL FOLDED UP POSITION

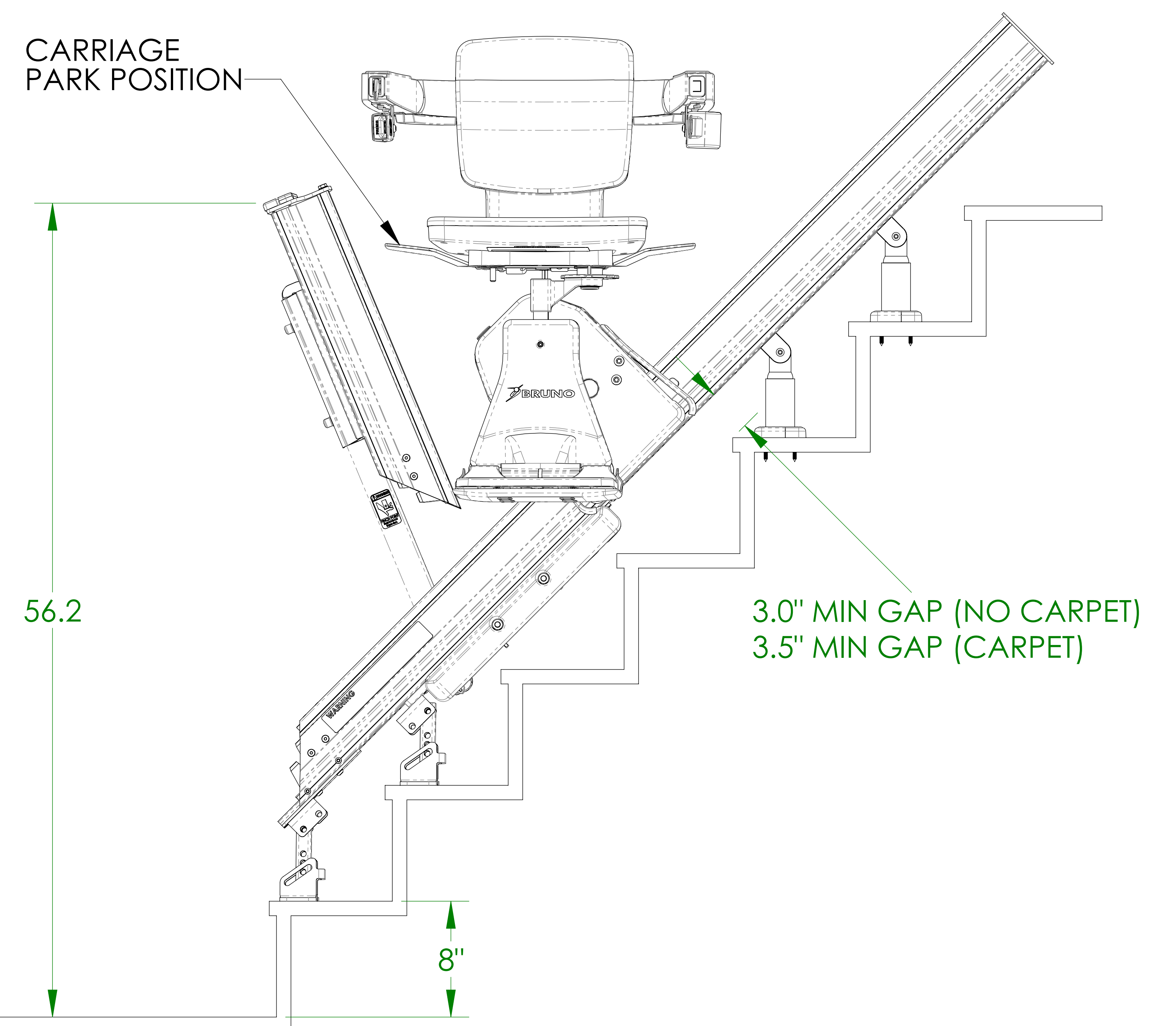

AUXILIARY ELEVATION VIEW
RAIL FOLDED DOWN POSITION

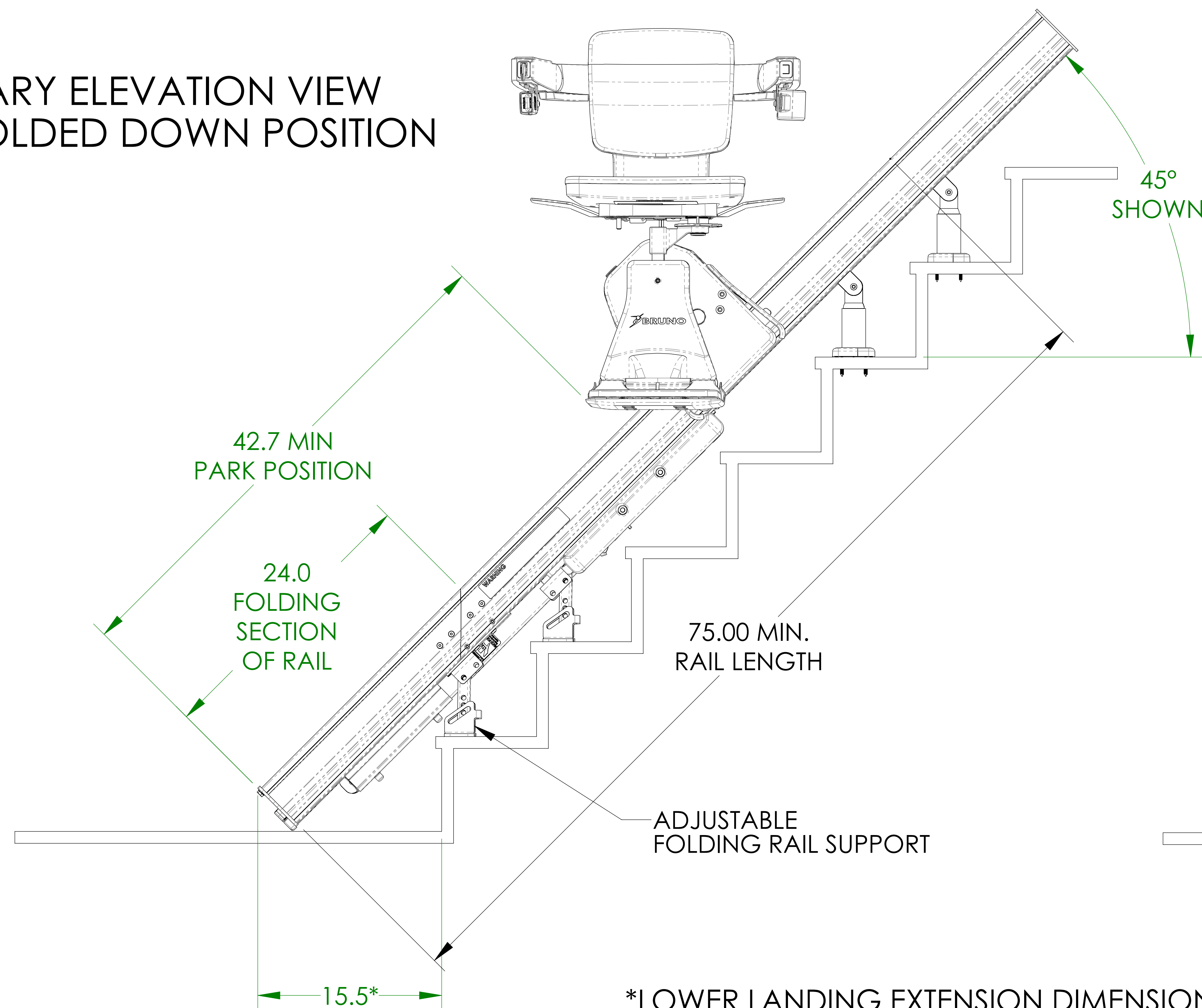

*LOWER LANDING EXTENSION DIMENSIONS ARE BASED ON 45° RAIL SLOPE AND 8" RISER HEIGHT. DIMENSIONS WILL VARY BASED ON SLOPE AND RISER HEIGHT.

1780 EXECUTIVE DRIVE
OCONOMOWOC, WI 53066
WWW.BRUNO.COM